

# SCYTEK ELECTRONICS ASTRA 50

## REMOTE KEYLESS ENTRY SYSTEM

### INSTALLATION & OPERATING INSTRUCTIONS

#### INTRODUCTION:

**CONGRATULATIONS** on your choice of a Remote Keyless Entry System by ScyTek Electronics Inc. This booklet contains the information necessary for installing, and operating your system. If any questions arise, contact your installation dealer or ScyTek Electronics Inc. at the Tech Support number below.

#### **\*IMPORTANT INFORMATION: Primary and Optional Features**

**-PRIMARY FEATURES:** These are features that must be connected in order for the system to operate properly i. e. Power & Ground, along with the Primary features of Power Locks & Flashing Lights.

**OPTIONAL FEATURES:** Optional features are connected only if desired or agreed upon by the installing dealer i. e. Driver's Separate Unlock, Horn Chirp, Dome light illumination, Trunk Pop, etc. These features may require additional parts and labor charges. Consult with your installer and come to an agreement about your optional features **before** installation. NOTE: The LED is required for programmable options. See page 8.

This device complies with FCC Rules part 15. Operation is subject to the following two conditions: 1) This device may not cause interference, and (2) this device must accept any interference that may be received, including interference that may cause undesired operation. The manufacturer is not responsible for any radio or TV interference caused by unauthorized modification to this equipment. Such modification could void the user's authority to operate the equipment.

#### TECH SUPPORT

Mon- Fri 8: 00 AM- 4: 30 PM Pacific Time

(800) 693-7505

[www.scytek.net](http://www.scytek.net)

email: [scytek@scytek.net](mailto:scytek@scytek.net)

## PRE- INSTALLATION CONSIDERATIONS

*To ease installation, we suggest that you READ THIS MANUAL before beginning your installation.*

**BEFORE BEGINNING** , check all vehicle manufacturer cautions and warnings regarding electrical service (AIR BAGS, ABS BRAKES, ENGINE / BODY COMPUTER AND BATTERY).

**PLAN OUT YOUR INSTALLATION** and determine most suitable locations for all components to be placed.

These components include: the module itself, valet/ program button and possible relays. Allow enough wire to create a service loop with strain relief, should servicing be required.

**DAMAGE** resulting from incorrect installation or failure to follow guidelines stated in this book will not be covered under warranty and subject to repair or replacement charges.

**USE A VOLT/ OHM METER** to test and locate all connections. Test Lights can damage a vehicle's computer systems.

**ADDITIONAL PARTS** , which are not included with this unit, may be needed for your particular vehicle. . These items may include extra relays (Part# CS- 402A) or Special "Data Bus" interface modules.

**DO NOT ROUTE ANY WIRING THAT MAY BECOME ENTANGLED** with brake, and gas pedals, steering column, or any other moving parts in the vehicle.

**REMOVE MAIN SYSTEM FUSE (S)** before jump starting the vehicle or charging the vehicles battery.

## COMPONENT MOUNTING

**CONTROL MODULE:** Locate the module underdash as high as possible. Driver's Side usually provides an easy location for the majority of the wiring connections. The antenna wire should be routed away from any metal if possible. DO NOT alter the length of the antenna wire, or ground the antenna wire.

**OVERRIDE / PROGRAM BUTTON:** Mount the button in a hidden but accessible location. It is used for emergency- disarm (when optional starter disable is installed) without the use of the transmitter and for programming features of this unit.

**LED :** The optional Red LED provides a useful theft deterrent. The LED blinks after you lock the vehicle with your remote simulating an alarm system. The LED is also required when programming options. Choose a visible location in the dash or console for the LED's location.

## WIRING

**WHITE WIRE: +12V or (-) NEGATIVE PARKING LIGHT (Jumper Selectable On- Board Relay 10A)**  
Connect to switched +12V parking light wire at back of light switch. If this is not possible, connect directly to one of the parking lights at the front of the vehicle. If your vehicle requires a (-) Negative Ground signal to activate the parking lights, then you have to open the control and move the jumper located on the circuit board inside the unit. For European vehicles with separate right and left circuits, use a dual relay or 2 diodes to separate the output signal. The **DEFAULT** output is POSITIVE.

**BLACK/ YELLOW WIRE: (-) AUXILIARY REMOTE OUTPUT 3 (Optional, requires relay)**  
This wire provides a Negative output for activation of optional or auxiliary devices. It is controlled by Pressing and Holding Buttons (2) Unlock and (4) Panic together.

**BLACK/ WHITE WIRE: (-) NEG. or +12V DOME LIGHT (Jumper Selectable On- Board Relay- 10A)**

Connect to dome light activation circuit for Negative type circuits. For Positive type circuits, open the control module and move the jumper the plug as shown in illustration.  
The DEFAULT is NEGATIVE.

**BLUE/ WHITE WIRE: (-) PASSENGER( S) DOOR UNLOCK OUTPUT (Optional, requires relay)**

Connects to unlock circuit for passenger door( s) when using separate driver's door unlock option. See DOOR

LOCK WIRING for configuration options.

**WHITE/ RED WIRE: (-) AUXILIARY REMOTE OUTPUT 2 (Optional, requires relay)**

This wire provides a Negative output for activation of optional or auxiliary devices. It is controlled by Pressing and Holding Button (1) Lock.

**ORANGE WIRE: NEGATIVE ARMED OUTPUT**

This wire provides a constant GROUND output when system is locked with the remote transmitter. This output can be used for a starter disable relay, or a device such as a window roll- up module. See System Wiring Diagram.

**GRAY WIRE: (-) AUXILIARY REMOTE OUTPUT 1 (Optional, requires relay)**

Negative output controlled by pressing Button #3 (Trunk Symbol) for at least 1 second.

**BROWN/ WHITE: (-) HORN HONK/ CHIRP OUTPUT (Optional, requires relay)**

This wire provides a negative pulse output to honk/ chirp the factory horn for audible lock/ unlock confirmation. Connect Brown/ White to terminal 85 of a relay. Connect terminal 86 to +12V Constant. Connect terminal 87 to +12V or GROUND depending on the type of horn activation circuit in the vehicle. Connect terminal 30 to the horn activation circuit. NOTE: Many vehicles use a Negative type of horn circuit, however we recommend that you test the circuit on your vehicle before making any connections to avoid any possible damage.

**GREEN WIRE: NOT USED (No Connection)**

**YELLOW WIRE: IGNITION SWITCHED "ON" AND "START" +12 VOLTS**

Connect to an ignition wire that shows +12 Volts when the key is in both "On" and "Start" positions.

**BLACK WIRE: SYSTEM CHASSIS GROUND**

THIS WIRE MUST BE CONNECTED TO CHASSIS METAL OF THE VEHICLE. Scrape away any paint or dirt from the connection point to ensure a good connection. Keep ground wire short.

**RED WIRE: +12V POWER INPUT (15 amp fuse)**

Connect to +12 Volt source with supplied fuse & holder. Recommended location for this connection is at the vehicle battery positive terminal.

## POWER DOOR LOCK WIRING

**6 PIN DOOR LOCK OUTPUT PLUG (On- Board Relays):**

**VIOLET (Fused 10A): UNLOCK Normally Open (Terminal 87 On- board Unlock Relay)**

**BROWN/ BLACK: UNLOCK Normally Closed (Terminal 87A On- board Unlock Relay)**

**BLUE/ BLACK: UNLOCK Output (Terminal 30 On- board Unlock Relay)**

**VIOLET/ BLACK (Fused 10A): LOCK Normally Open (Terminal 87 On- board Lock Relay)**

**WHITE/ BLACK: LOCK Normally Closed (Terminal 87A On- board Lock Relay)**

**GREEN/ BLACK: LOCK Output (Terminal 30 On- board Lock Relay)**

# POWER DOOR LOCK WIRING

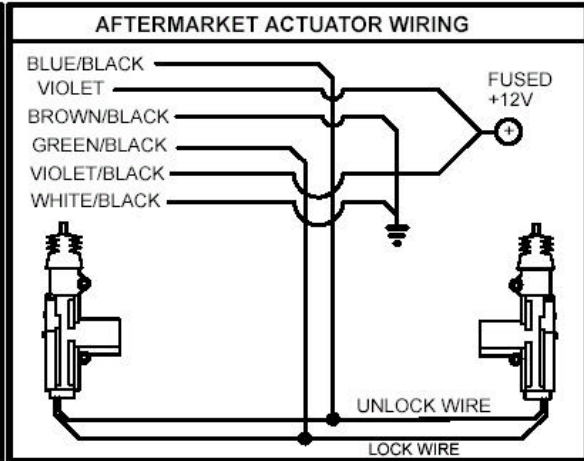
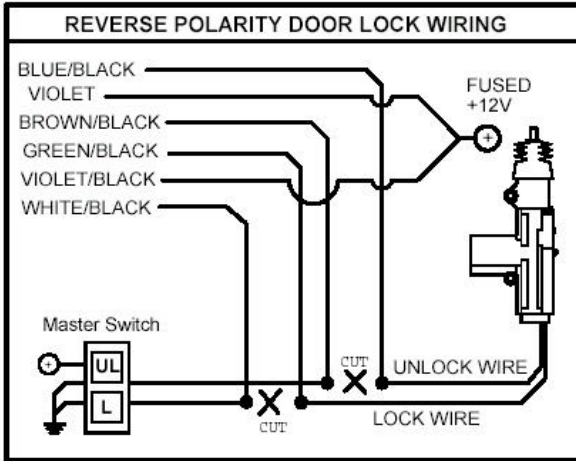
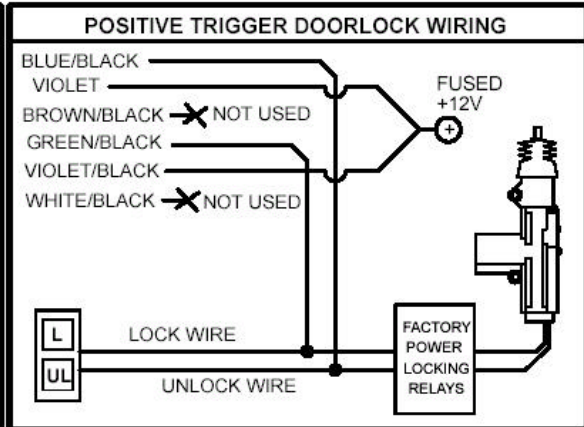
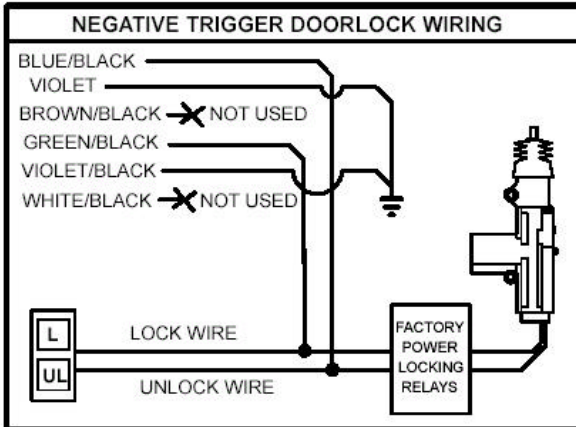

## SEPARATE DRIVER'S DOOR UNLOCK DIAGRAMS

### DRIVER PRIORITY UNLOCK with NEGATIVE TYPE DOOR LOCKS

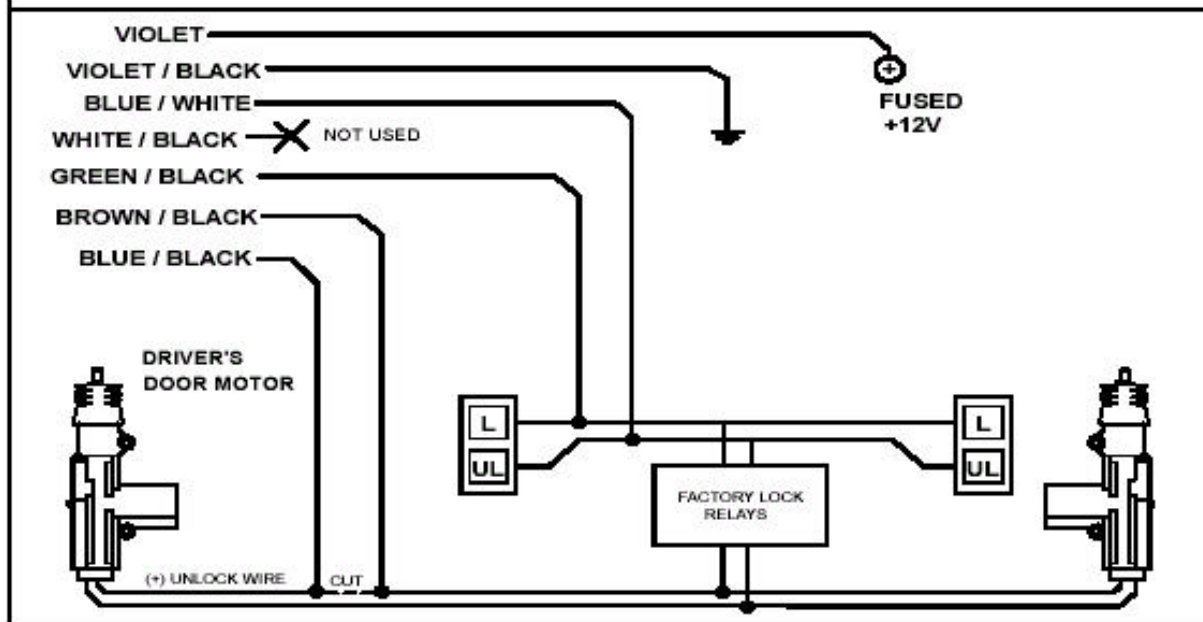

### DRIVER PRIORITY UNLOCK with REV. POLARITY DOOR LOCKS

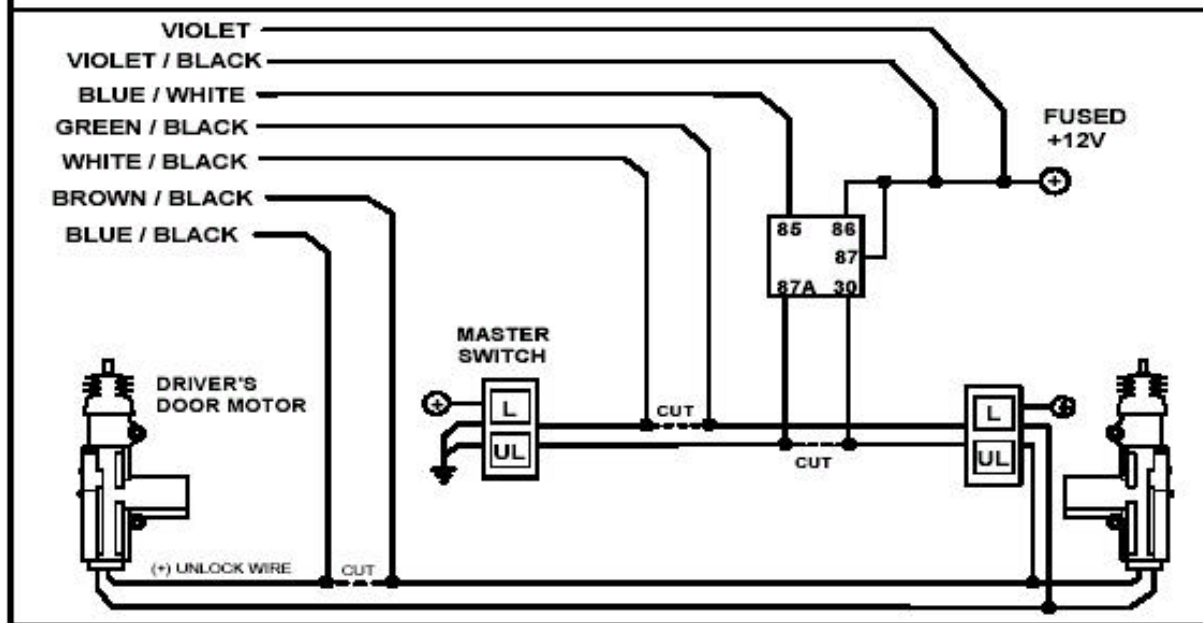

## JUMPER PIN DIAGRAM

The jumper plugs inside the control module determine the unit's (+12V) or (-) Negative Parking & Dome Light Relay outputs (White & Black/White wires). Use the jumper pins to change the Positive or Negative Polarity of the outputs as required for your particular installation. (Default = Positive for Parking Light and Negative for Dome Light) See diagram below.

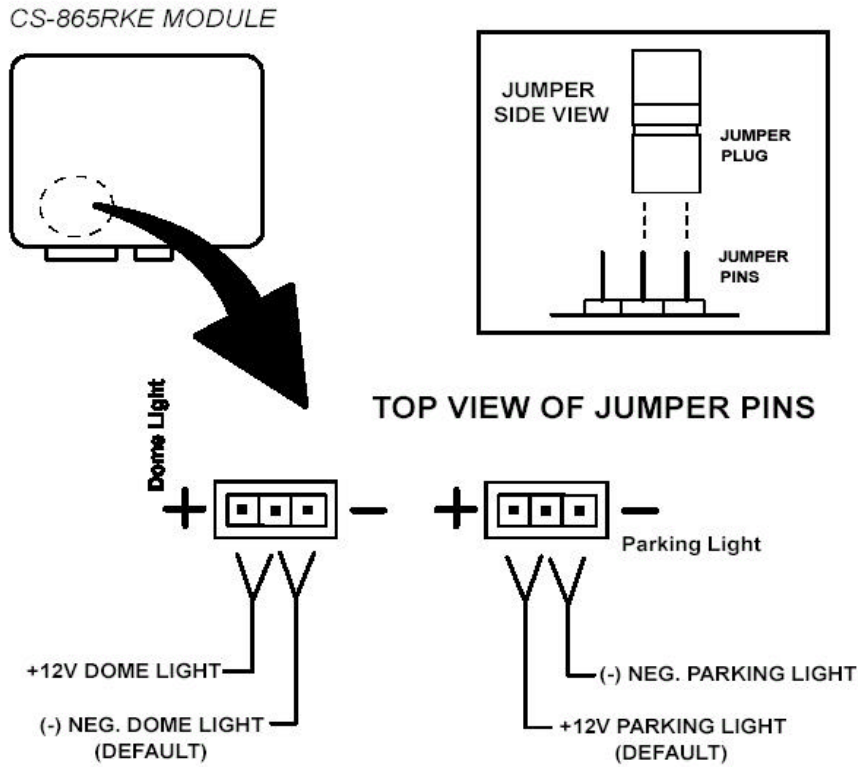

# SYSTEM WIRING DIAGRAM

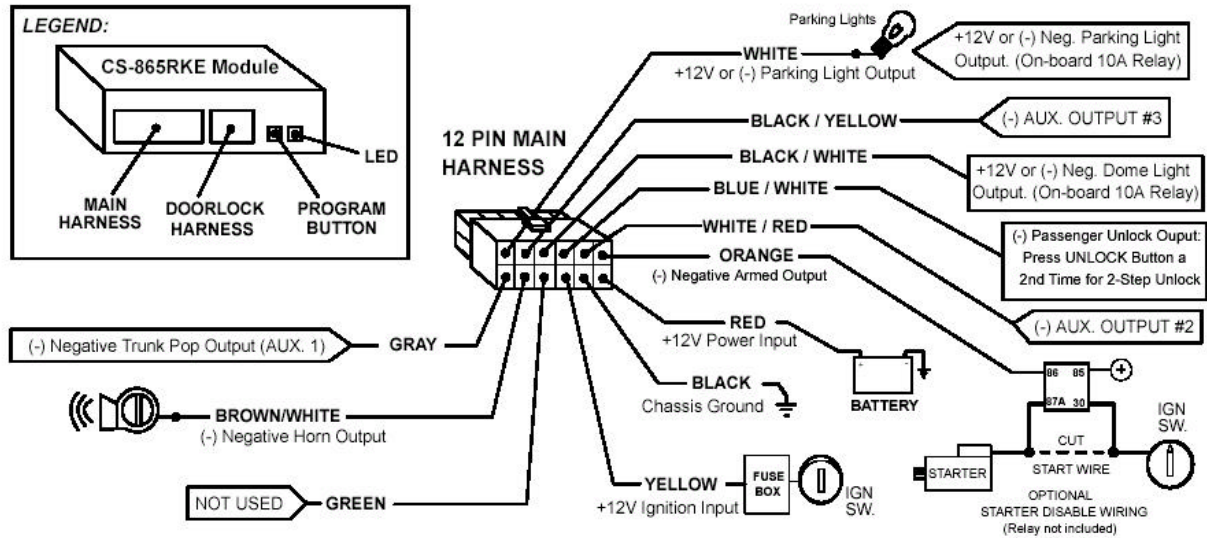
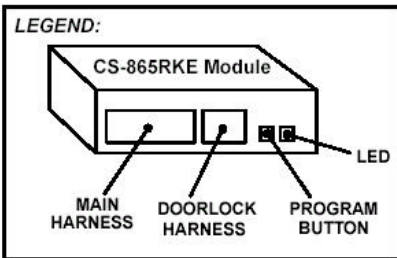
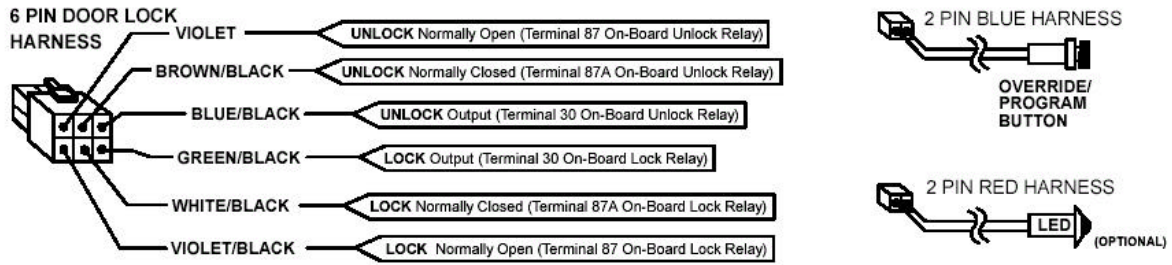

## TRANSMITTER PROGRAMMING

- Turn Ignition ON and OFF 3 times quickly, leaving it ON the 3<sup>rd</sup> time. (ON/OFF, ON/OFF, ON)
2. Lights should flash 3 times & horn will chirp 3 times if horn feature is installed.
3. Push and hold the Program/Override Button for about 5 seconds until you get 3 lights/LED flashes & 3 Horn chirps. Release the button.
4. Press the #1 (LOCK) on transmitter to learn. Lights will flash for code learn confirmation.
5. Repeat step 3 for up to 2 additional transmitters. The system will learn a total of 3 transmitter codes.
6. Turn off Ignition. System will flash lights 3 times and chirp 3 times when exiting programming mode.

## OPTION PROGRAMMING

To change programmable options, follow steps below. LED Must be installed or plugged into control module for programming options.

1. Turn the Ignition ON, wait one second, and press the Override/Program button 5 times.
2. The system will flash the LED 5 times
3. Within the next few seconds, press the Override/Program button [again] the number of times that corresponds to the options chart below. Parking lights and/or optional horn should chirp for each button press. Don't lose count!
4. When you get to the desired option number, quickly press the appropriate button on the remote control according to the chart below. The system will provide 1 chirp/flash for Button 1 (Lock Symbol) and 2 chirps/flashes for button 2. (See Option Chart for numbers, descriptions, and values.)
5. Turn Ignition off. Change ONE option at a time repeating these same steps 1-4. When you are finished customizing options, check operation to see if the option(s) have changed.

### PROGRAMMING OPTIONS CHART \* = DEFAULT SETTING

Option #	Option Description	Selection	Lock Button	Unlock Button
1.	Auto Lock & Unlock with Ignition	ON or OFF	ON*	OFF
2.	Double Unlock Pulse	ON or OFF	OFF*	ON
3.	Horn Chirp	ON or OFF	ON*	OFF
4.	Lock/Unlock Pulse Time	0.8 Sec. or 3 Sec.	0.8 Sec.*	3 Sec.
5.	Passive Starter Disable	ON or OFF	OFF*	ON
6.	Ignition Trigger	ON or OFF	OFF*	ON
7.	Extended Horn Chirp	Normal or Extended	Normal*	Extended

#### 1. AUTOLOCK / UNLOCK WITH IGNITION

Controls whether the doors will automatically lock when the ignition is turned on and will unlock when the ignition is turned off. **Note: When Separate Driver's Door Unlock feature is installed, only driver's door will unlock when IGN. is turned off.**

#### 2. DOUBLE UNLOCK PULSE

The unit will send 2 unlock pulses when the #2 Unlock button is pressed. This feature may be required for interfacing this system into specific makes and models of vehicles that require this function.

#### 3. HORN CHIRP CONFIRMATION

This option turns the horn chirps for lock/unlock on or off.

#### 4. DOOR LOCK/UNLOCK PULSE TIME

Controls the amount of time (0.8 sec. or 3 sec.) for the lock/unlock pulse. The 3 sec. setting may be required for 1980'/90's European Vehicles that require a long pulse to operate electric vacuum type door lock systems.

#### 5. PASSIVE STARTER DISABLE OUTPUT (Applies to OPTIONAL starter disable feature)

This option modifies the unit's (-) Negative Armed Starter Disable output operation. When this option is turned ON, the unit will PASSIVELY activate the Starter Disable 45 seconds after the ignition is turned off. Starter disable output is deactivated through the remote when unlocking the vehicle or a manual override.

#### **6. IGNITION TRIGGER**

This option controls the unit's optional Ignition trigger feature. If selected to ON, then the vehicle's horn will honk if an unauthorized operator turns on the Ignition after the vehicle had been locked with the remote. This function is similar to an alarm system. To avoid a trigger, use the remote for BOTH LOCKING and UNLOCKING the vehicle. If system accidentally triggers, press button #4 to reset.

#### **7. EXTENDED HORN CHIRP**

This option allows the unit to provide a slightly longer lock/unlock horn chirp output. This option is ONLY required on specific vehicles where the normal horn chirp is not long enough to activate the factory horn and produce a chirp.

#### **OPTION RESET: RESTORES PROGRAMMING OPTIONS TO FACTORY DEFAULT SETTINGS:**

1. Turn the Ignition ON, wait one second, and press the Override/Program button 5 times.
2. The system will flash the LED 5 times
3. Press Button #3 (Trunk). Lights will flash 4 times and horn will chirp (if optional horn chirp installed) 4 times. All options will be returned to factory default setting. Default settings are marked with an “\*\*”

## **OPERATION**

### **REMOTE LOCK**

To lock the doors, press the #1 (Lock Symbol) button on the transmitter. Lights will flash once and LED will begin flashing. You will also hear a single horn chirp (if optional horn chirp feature is installed). Optional: If starter disable is installed, it will also become active.

### **REMOTE UNLOCK**

To unlock the doors, press the #2 (Unlock Symbol) button on the transmitter. Lights will flash 2 times. You will hear 2 horn chirps (if horn chirp installed). Optional: Starter disable will turn off.

### **SEPARATE DRIVER'S DOOR UNLOCK (OPTIONAL)**

When using the Optional Separate Driver's & Passenger unlock, also known as “Driver's Priority” or “2 Stage” unlock, press the #2 Unlock button once to unlock the driver's door and a second time to unlock remaining door as needed. Lights will flash 2 times on the first press and then one more time on the second press.

To sound the panic alarm in an emergency situation or to draw attention to your vehicle press and hold Button #4 (Panic) for at least 2 seconds. The horn will begin to pulse and parking lights will flash for up 45 seconds or until the Panic Button on the transmitter is pressed again to reset this mode.

### **TRUNK / HATCH POP (REMOTE AUX. OUTPUT 1, OPTIONAL)**

To pop the trunk (Optional), press Button #3 (Open Trunk Symbol) on the transmitter for at least 2 seconds. There is a slight delay on this function. This is an intentional delay to help prevent your trunk or hatch from opening accidentally when the remote is in your pocket or purse.

### **2<sup>nd</sup> AUX. OUTPUT (REMOTE AUX. OUTPUT 2, OPTIONAL)**

To activate the Second auxiliary output press and hold Button #1 (Lock) and hold for more than (1) second. This output can be used to control other optional add-on accessories such as a Remote Engine Start Module.

### **3<sup>RD</sup> AUX. OUTPUT (REMOTE AUX. OUTPUT 3, OPTIONAL)**

To activate the Third auxiliary output press and hold Buttons #2 (Unlock) and #4 Panic together. This output can be used additional accessories.

**#3#1#2#4PANICTRUNKPANICLOCKUNLOCKREMOTE**

### **IGNITION TRIGGER (OPTIONAL REQUIRES HORN HONK FEATURE)**

This optional feature allows the unit to activate the panic mode if an unauthorized operator turns the Ignition ON after the vehicle had been locked *using the remote control*. This is not alarm system that can be triggered when opening the door, however with this feature is will trigger if the Ignition is turned on if you choose. To avoid an Ignition trigger, use the remote for BOTH LOCKING and UNLOCKING the vehicle. When the Ignition trigger occurs, press button #2 (Unlock) on the remote or if you don't have a remote then perform an Emergency Override. See Below for Emergency Override.

**VALET MODE**

To get in and out of VALET mode, turn the ignition on and press the override/program button for about 7-8 seconds. When going into VALET you will get (1) horn chirp, (1) light flash, and LED will be on SOLID. When coming out of VALET mode you will get (2) Chirps, (2) Flashes, and LED will go out. The Optional Starter Disable feature (if installed) will not operate when in VALET mode.

**EMERGENCY OVERRIDE (MAY BE NEEDED WHEN OPTIONAL STARTER DISABLE INSTALLED)**

If you have lost the transmitter or it stops working for any reason and the system was locked with the remote Emergency Disarm is needed to override the Starter Disable circuit. Open the door with the key manually, turn the ignition on and press the override/program button for 7-8 seconds. You will get (1) short horn chirp and (1) light flash which will put the system into VALET mode. If Optional LED light is installed, it will turn ON and stay on solid while in VALET mode.

**AUTO LOCK / UNLOCK WITH IGNITION**

The doors will automatically lock when the ignition is turned on and will unlock when the ignition is turned off. If this is not desired, see the Option Programming section to change this feature.

**HORN HONK/CHIRP FEATURE (OPTIONAL)**

This system can provide short chirps of your Factory Car Horn along with the Flashing Parking lights for Lock/Unlock confirmation. This optional feature requires additional installation. Once installed, the horn chirp feature can also be turned ON or OFF in the Option Programming Section.

**DOME LIGHT ILLUMINATION (OPTIONAL)**

This feature turns on the vehicles dome light upon disarm for 30 seconds or until the key is inserted and turned on. This will provide illuminated entry to your vehicle at night or in dimly lit areas for safety and security. This feature requires additional installation.