

REMOTE KEYLESS ENTRY

INSTALLATION MANUAL

**BEFORE INSTALLING THIS PRODUCT PLEASE READ
THIS INSTALLATION MANUAL THOROUGHLY!!**

- This product must be installed by qualified personnel according to these instructions.

Items Included:

- Main unit
- Two 4-button remote transmitters
- Plug In LED
- Plug in program switch
- Main harness
- Owner's manual

Before you begin the installation:

- Verify with the customer the desired location for the program switch and LED.
- Always use a multimeter when verifying vehicle wiring.

Installation Notes:

- Do not install the main unit in the engine compartment.
- Make all wiring connections to the vehicle before connecting the main 15-pin connector harness to the main unit.
- Mount the main unit in a secure area, away from vehicle computers and heating/air conditioning ducts. The location should be convenient for your installation, but hidden from thieves. Mount the unit as far away from metal objects as possible to

increase the range of the remote transmitters.

- When running the harness wires through the vehicle, be careful to run them where they cannot be damaged or shorted. Keep them away from any moving parts or areas of high heat. Use rubber or plastic grommets to protect the harness wires where they pass through holes in metal panels.

Main Harness:

- BLACK WIRE - Ground input (-). Connect to a solid chassis ground that is clean and free of paint or dirt.
- RED WIRE - +12V battery input.
- WHITE WIRE - Parking light output (+). Connect to the wire that shows +12V when the parking lights are turned on. If the vehicle's parking light circuit exceeds 10A, a relay is required. For vehicle's with independent left and right parking light circuits, the parking light wires must be connected using diodes to keep the circuits separate.
- VIOLET WIRE - Unlock #87 normally open input 10A fuse. (see *Door Lock Wiring Diagrams*)
- BLUE/BLACK WIRE - Unlock #30 common output. (see *Door Lock Wiring Diagrams*)
- BROWN/BLACK WIRE - Unlock #87A normally closed input. (see *Door Lock Wiring Diagrams*)
- VIOLET/BLACK WIRE - Lock #87 normally open input 10A fuse. (see *Door Lock Wiring Diagrams*)

- GREEN/BLACK WIRE - Lock #30 common output. (see *Door Lock Wiring Diagrams*)
- WHITE/BLACK WIRE - Lock #87A normally closed input. (see *Door Lock Wiring Diagrams*)
- ORANGE WIRE - Armed Output (-) 500Ma. The ORANGE wire provides ground when the unit is armed to activate a starter disable relay. Connect to a relay for starter defeat.. (See *Relay Wiring Diagrams*)
- BLACK/YELLOW - Dome light output (-) 500mA. Connect to a relay to activate the dome light when the system is unlocked. (See *Relay Wiring Diagrams*)
- GRAY WIRE - 3rd channel output (-) 500mA. Connect to a relay for optional trunk release etc. (See *Relay Wiring Diagrams*)
- BROWN WIRE - Horn honk output (-) 500mA. Connect to a relay to honk the vehicle's horn. (See *Relay Wiring Diagrams*)
- BLUE/WHITE WIRE - Passenger unlock output (-) 500mA. The BLUE/WHITE wire provides a ground to unlock the passenger doors when the unlock button on the transmitter is pressed two times. To install the two-step unlock feature, the BLUE/BLACK and BROWN/BLACK wires must be run directly to the driver's door actuator unlock wire and the BLUE/WHITE wire must be connected to a relay to unlock the passenger doors. (see *Optional Two-Step Unlock Diagrams*)
- YELLOW WIRE - Ignition input (+). Connect to the main ignition wire that switches +12V and does not drop out during cranking.

2-Pin Red Connector: Plug-in connector port for LED. Mount LED in an area where it may be easily seen from either side of the vehicle.

2-Pin Blue Connector: Plug-in connector port for program/service switch. Mount program switch in an area that is easily accessible from the driver's position.

Adding or Deleting Remote Controls

When you enter the code learning mode, the system will learn new remotes and automatically delete all other remotes that were previously operating the system.

NOTE: You must code all desired remotes at this time. The unit can learn a maximum of three transmitters.

To enter Code Learning Mode:

1. Turn ignition key on, off, on, off, on and leave on within 5 seconds. The horn will chirp once (if installed) and the LED and parking lights will flash once.
2. Press and hold program switch for 2 seconds. The horn will chirp three times and the LED and parking lights will flash three times.
3. Release the program switch.
4. Program all desired remotes by pressing button 1 on each of the transmitters. The parking lights will flash after the system has learned each remote control.
5. Turn ignition key off. Remotes are now programmed to the system.

Remote Programmable Features:

Step	Function	Button 1 (Default)	Button 2
1.	Ignition Controlled Door Locks	On	Off
2.	Door Unlock Pulse	Single	Double
3.	Arming Mode	Standard	Silent
4.	Door Lock Pulse Length	.75 Seconds	3 Seconds
5.	Passive Starter Defeat Enable	Off	On
6.	Ignition Trigger Feature	Off	On

Remote Programmable Features

To enter program mode:

1. Turn Ignition to the on position.
2. Wait 2 seconds.
3. Within 10 seconds press program switch 5 times.
4. The LED and parking lights will flicker to indicate the system is now in program mode.

To change programmable features:

Press program switch the number of times equal to the feature you wish to change. The LED will flash each time the switch is pushed. (Example: to program feature #3 press the program switch 3 times).

- Press button 2 (Unlock) on the remote to change the feature. The LED will flash twice.
- Press button 1 (Lock) on the remote to reset the feature back to default (factory) setting. The LED will flash once.

System will automatically exit program mode.

Programmable Features

Program #1: Ignition Controlled Door Locks.

- Button 1 = Doors lock with ignition
- Button 2 = Doors do not lock with ignition

Program #2: Door Unlock Pulse

- Button 1 = Single
- Button 2 = Double

Program #3: Optional Horn Mode

- Button 1 = Chirp with Lock/Unlock

Button 2 = Silent

Program #4: Door Lock Pulse Length

- Button 1 = 0.5 second door lock/unlock pulse
- Button 2 = 3 second door lock/unlock pulse

Program #5: Passive Starter Defeat

- Button 1 = Normal
- Button 2 = Starter defeat activates 45 seconds after ignition is turned off

Program #6: Ignition Trigger Feature

- Button 1 = Off
- Button 2 = On

Default Reset

To reset all programmable features to their factory default settings:

1. Turn ignition to the on position.
2. Wait 2 seconds.
3. Within 10 seconds press program switch 5 times. The LED and parking lights flicker to indicate the system is now in program mode.
4. Press transmitter button 3 (Trunk). The LED will flash 3 times, pause then continue flashing. All programmable features will be reset to the default position.

TROUBLESHOOTING

Problem	Probable Cause	Suggested Correction
Unit will not go into Code Learning Mode.	RED or YELLOW wire not connected to the correct power source. Code Learning sequence performed too slowly.	RED wire should connect directly to the battery. Connect YELLOW wire to true ignition wire (NOT AT FUSE BLOCK). Perform Code Learning sequence faster.
Remote transmitter does not lock and unlock the vehicle.	Defective remote transmitter. Remote transmitter battery needs replacement. Antenna wire is grounded.	Replace remote transmitter or its battery. Check antenna wire for short to ground.
Remote transmitter range is poor	Unit is picking up interference from vehicle's electrical system.. Antenna wire is grounded.	Make sure antenna is not connected to anything or shorted to ground. Relocate unit away from vehicle computer modules
Override switch does not work.	Bad switch or switch is not pressed long enough to active.	Repair/replace switch. Press switch
Flashing light output does not work.	Bad connection on WHITE wire or the output polarity is wrong for the circuit being driven.	Check WHITE wire. Connect a SPDT relay to this wire and apply the opposite polarity to the circuit being driven.
Door locks do not lock/unlock correctly, or action is reversed	Wrong door lock polarity. Wrong lock wires connected.	See Door Lock Wiring Diagrams for correct wiring. Verify vehicle lock/unlock wires.
Dome light does not turn on upon unlock	Dome light relay not installed. Wrong polarity selected.	Install dome light relay. Change polarity of dome light relay.

KEYLESS ENTRY WIRING DIAGRAM

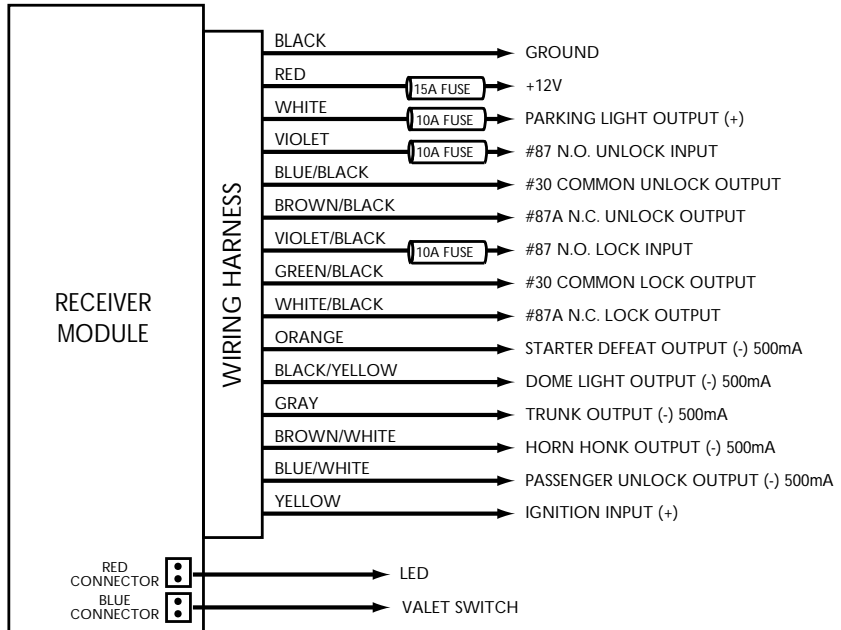

DOOR LOCK WIRING DIAGRAMS

NEGATIVE PULSE DOOR LOCK SYSTEM

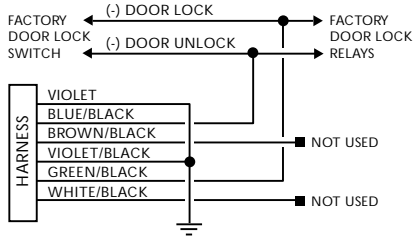

POSITIVE PULSE DOOR LOCK SYSTEM

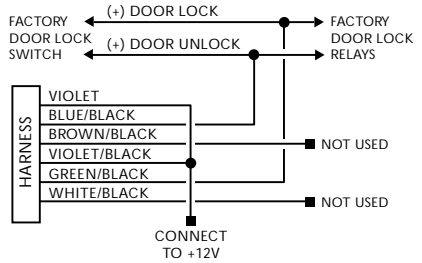

ADDING ACTUATORS

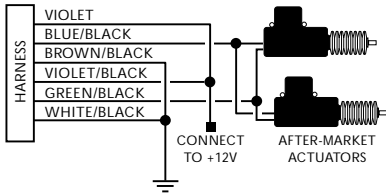

VACUUM DOOR LOCK SYSTEM

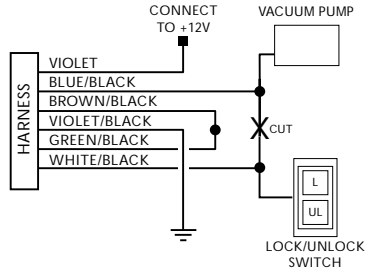

REVERSE POLARITY DOOR LOCK SYSTEM

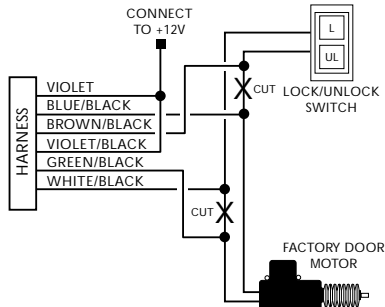

OPTIONAL TWO-STEP UNLOCK WIRING DIAGRAMS

TWO-STEP UNLOCK NEGATIVE PULSE

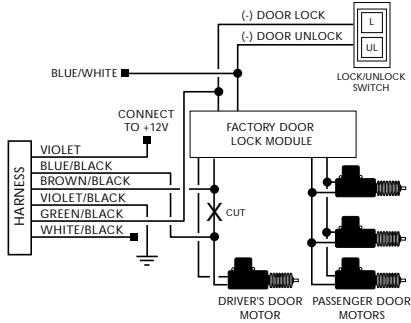

TWO-STEP UNLOCK POSITIVE PULSE

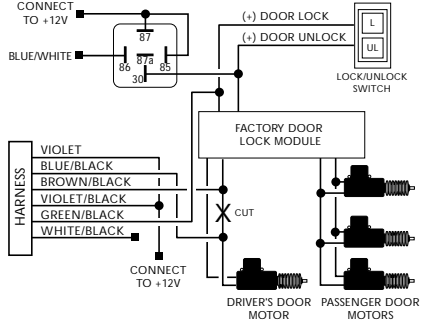

TWO-STEP UNLOCK REVERSE POLARITY

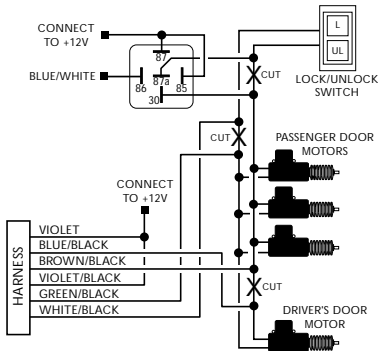

TWO-STEP UNLOCK ADDING ACTUATORS

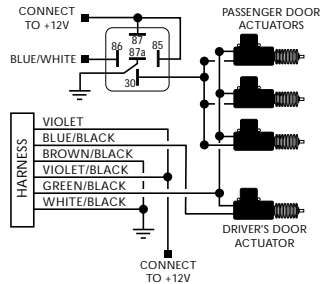

RELAY WIRING DIAGRAMS

STARTER DEFEAT

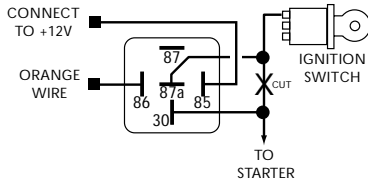

TRUNK RELEASE DIAGRAM

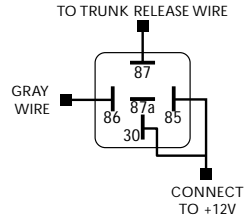

DOME LIGHT DIAGRAM

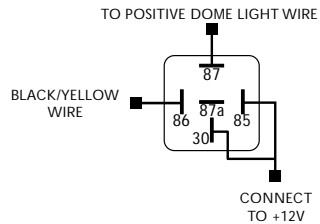
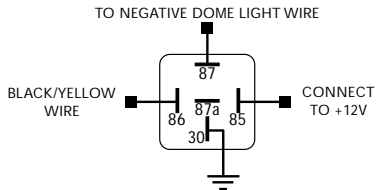

HORN HONK DIAGRAM

